

PMD3 Plus Elliptic[®]

CEIA An
ISO 9001 Company



with **BUILT-IN GAMMA PORTAL MONITOR**

ENHANCED WALK-THROUGH METAL AND GAMMA DETECTOR



METAL DETECTOR FEATURES

- Accurate Detection of magnetic, non-magnetic and mixed-alloy metal weapons
- Multi-Zone target indication over the entire transit area
- Extremely High Discrimination and flow rate
- Very High Immunity to electromagnetic and mechanical interferences
- Detection of radioactive substance shielding containers
- Compliant with and certified to the applicable Standards for Enhanced Metal Detectors



GAMMA DETECTOR FEATURES

- Detection of Gamma emitting threats
- Embedded, high-sensitivity, full-height radiation sensors for uniform coverage of the transit area
- Multi-Zone indication of Gamma Sources
- Compliant with and certified to the applicable detection requirements for Gamma Portal Monitors

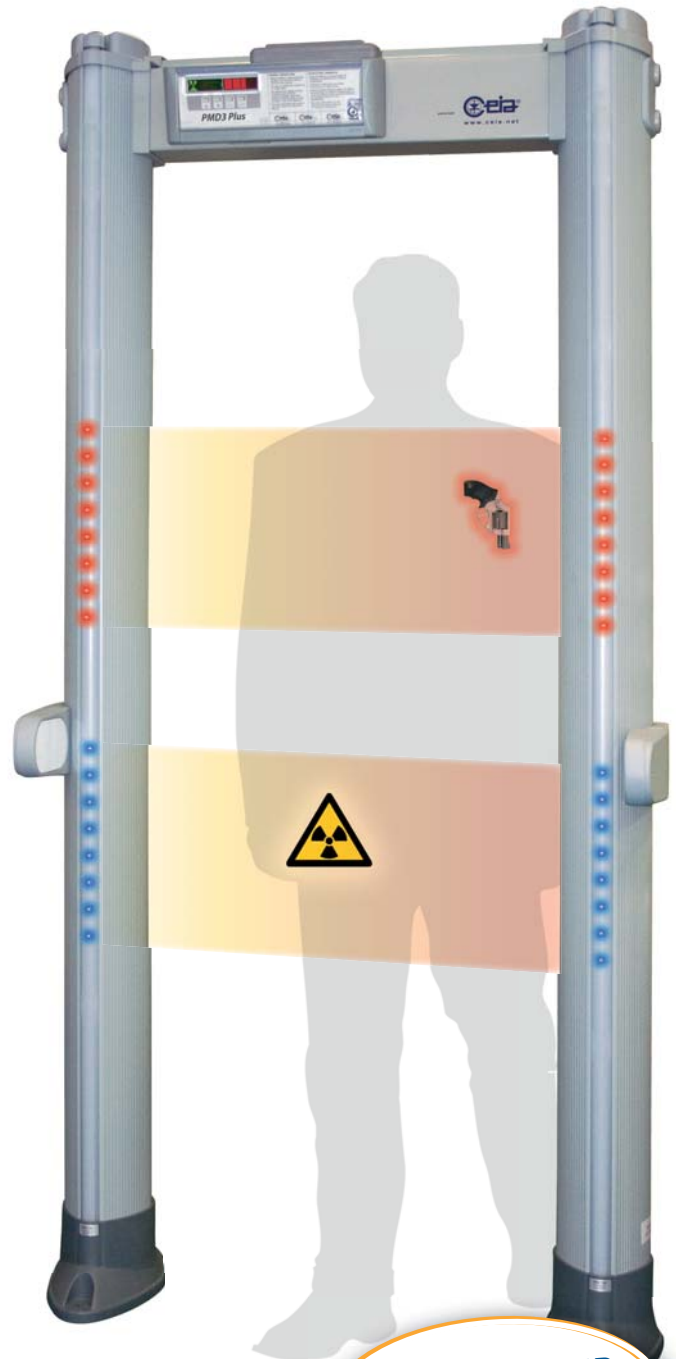

**FOR FIXED AND
PORTABLE USE**



www.ceia.net

CONFIDENTIAL: this document is property of CEIA which reserves all rights. Total or partial copy, modification and translation is forbidden.

CEIA reserves the right to make changes, at any moment and without notice, to the models (including programming), their accessories and options, to the prices and conditions of sale

PMD3 Plus Elliptic®

ENHANCED WALK-THROUGH METAL AND GAMMA DETECTOR

The **PMD3 Plus Elliptic** is a Walk-Through Weapons and Gamma Radiation Detector that combines two advanced detection technologies in a single lightweight Elliptic Portal

TWO ADVANCED DETECTION TECHNOLOGIES

Metal weapons such as miniaturized assembled and disassembled firearms, in magnetic and/or non-magnetic metal, are detected independent of their orientation and position of transit, thanks to an extremely uniform inspection field.

At the same time, innocuous items, such as keys, coins, shoe shanks and belt buckles, are effectively discriminated thus **reducing the nuisance alarm rate five or more times** compared with other available metal detection systems.

The **PMD3 Plus Elliptic** is also equipped with an array of sensitive gamma sensors, covering the full height of transit, allowing **accurate detection of radioactive substances carried by the people in transit**. The detection capability includes a wide range of energies for a complete coverage of the possible radioisotopes.

The gamma detectors adapt themselves to the background radiation level, adjusting the threshold to the optimum value for the installation environment.

At the same time, a special algorithm prevents the adaptation to unusual background levels and changes.



www.ceia.net

PMD3 Plus Elliptic®



The gamma-ray detection technology utilized in the **PMD3 Plus Elliptic** has been tested in Government-Authorized Laboratories

PREVENTION OF RADIOACTIVE SUBSTANCE SHIELDING

Any attempt to smuggle radioactive substances using masking containers is effectively prevented by a specific detection function.

Two advanced detection technologies are therefore combined in order to enhance each single capability.

HIGH LEVEL OF ELECTRONIC AND MECHANICAL RELIABILITY

The overall system is characterized by sturdy, reliable electronic and mechanical construction, ease of installation, automatic reset calibration and very high immunity to external electrical and mechanical interference.

The **PMD3 Plus Elliptic's** refined, elegant design can be used in the most demanding architectural environments. The unique patented design of the gate is compact and easy to install while utilizing minimal amounts of space. The lightweight design of the gate is perfectly suited for portable applications.

CHECKPOINT SECURITY COVERAGE USING THE **PMD3 Plus Elliptic** AND GAMMA OPTION CAN BE COMPLETED BY A **G-SCAN** DETECTOR POSITIONED AT THE EXIT OF THE HAND-LUGGAGE INSPECTION X-RAY MACHINE



www.ceia.net

PMD3 Plus Elliptic®

ALARM SIGNALLING

The **PMD3 Plus Elliptic** is an integrated Metal and Gamma Detector Portal, designed to detect metal and radioactive threats simultaneously.

Metal weapons, gamma sources and shielding containers are indicated on the bar display with appropriate optical signals. Threat transit zones are indicated by means of 20 independent optical indicators.

All detection data and programming operations are available through the Network monitoring software (see current NetID literature).

Two different Alarm Signalling modes can be set, according to the preferred operating procedures:

LOCAL MODE

- **METAL WEAPONS:** *acoustic alarm, position indication by red color zone and bar-graph intensity on the control unit.*
- **RADIOACTIVE SOURCES:** *dedicated acoustic alarm, position indication by blue color zone and bar-graph intensity on the control unit.*

Detection of metal threats and radioactive sources carried by the same transiting person are displayed simultaneously.

REMOTE MODE*

- **METAL WEAPONS:** *acoustic alarm, position indication by red color zone and bar-graph intensity on the control unit.*
- **RADIOACTIVE SOURCES:** *intensity and position remotely alarmed through network monitoring software to a supervisor station.*

In remote-operation mode, local display of alarms caused by radioactive substances can be deactivated.

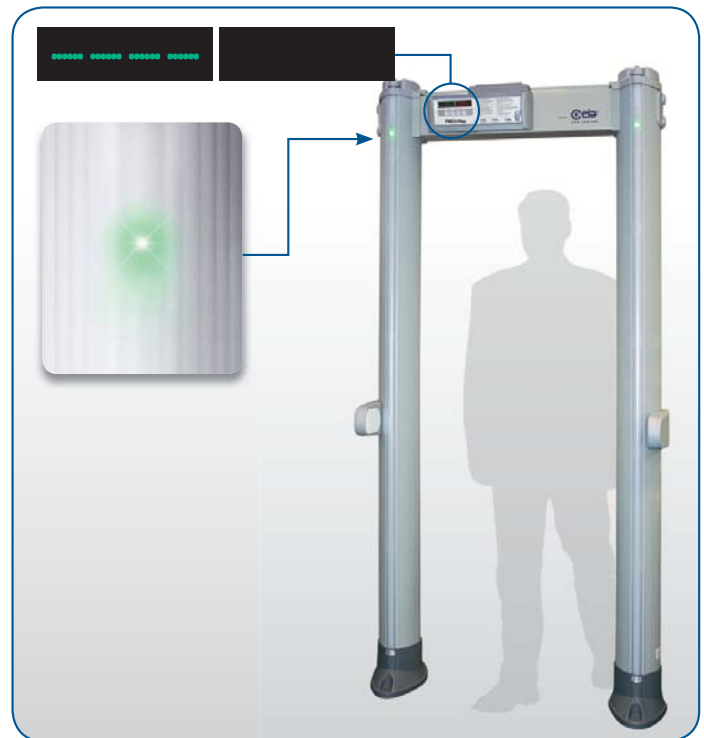

➤ SYSTEM READY AND WAITING FOR TRANSITS

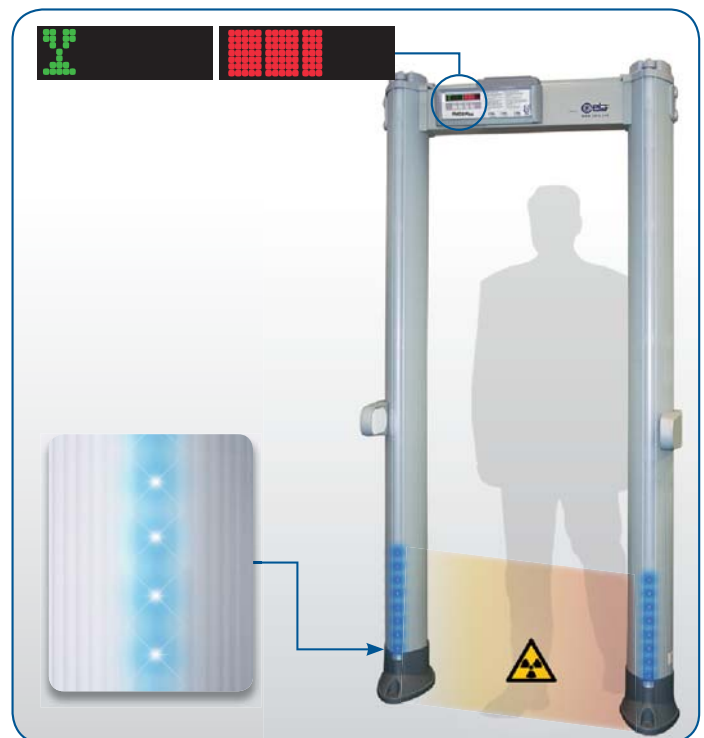

➤ RADIOACTIVE SUBSTANCE DETECTION (LOCAL MODE)

METAL SIGNAL UNDER THE ALARM THRESHOLD	
	Small metal mass
	Medium metal mass
METAL SIGNAL OVER THE ALARM THRESHOLD	
	Medium metal mass
	Large metal mass

GREEN AND RED METERING SIGNALS PROPORTIONAL TO THE METAL MASS OF THE DETECTED THREAT

GAMMA SIGNAL UNDER THE ALARM THRESHOLD	
GAMMA SIGNAL OVER THE ALARM THRESHOLD	

RED METERING SIGNALS PROPORTIONAL TO THE INTENSITY OF THE RADIOACTIVE THREAT (DISPLAYED ON THE CONTROL UNIT ONLY IF ENABLED)

* See NetID literature for more information on Remote Mode

PMD3 Plus Elliptic®

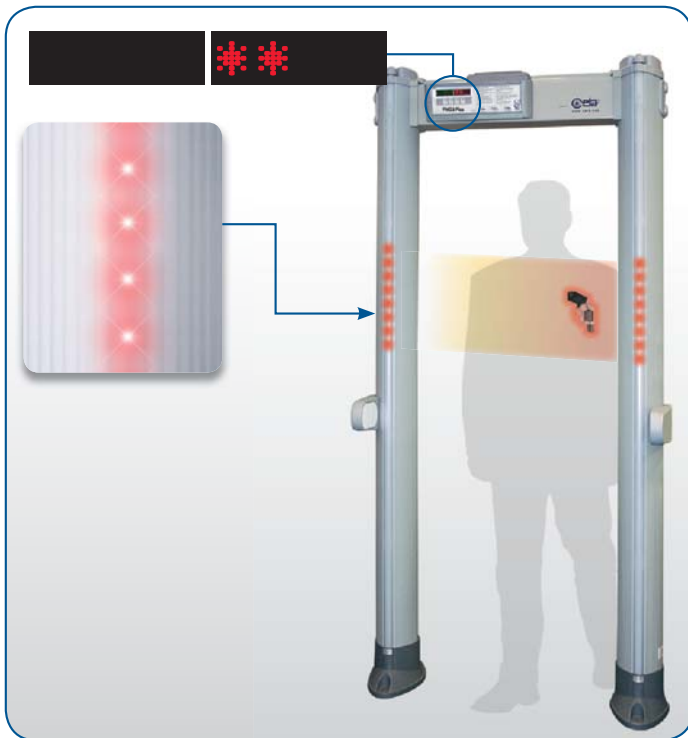

➤ SINGLE METAL THREAT DETECTION AND INDICATION

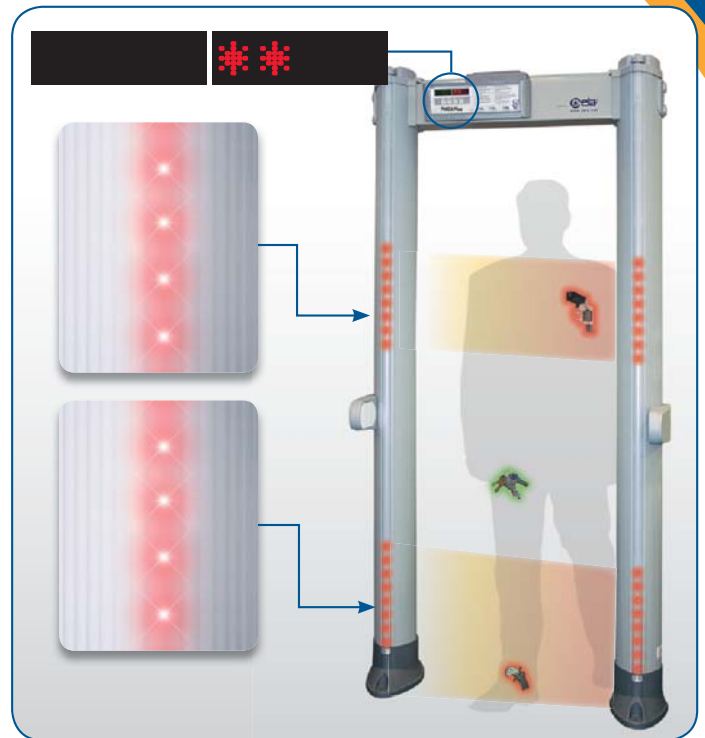

➤ MULTIPLE METAL THREATS DETECTION AND INDICATION

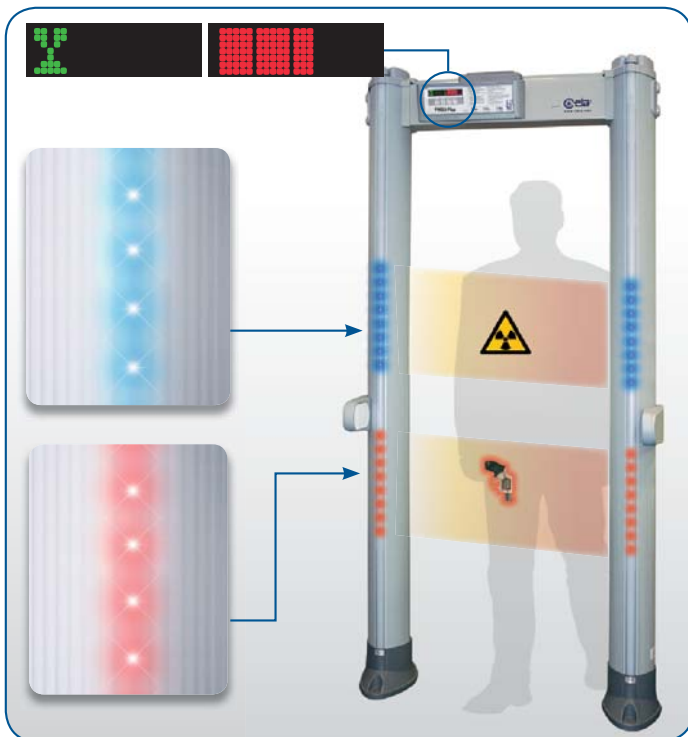

➤ SIMULTANEOUS DETECTION OF A METAL THREAT AND A RADIOACTIVE SUBSTANCE (LOCAL MODE)



➤ SHIELDING CONTAINER DETECTION

PMD3 Plus Elliptic®

CEIA **Net ID**® NETWORK SYSTEM FOR REMOTE CONTROL OF CEIA INSPECTION EQUIPMENT

The NetID System manages CEIA inspection equipment and stores the information in a centralized database

The system is accessed via the NetID suite of multi-user software applications which is resident on a dedicated machine (NetID ELSA) and can be called up by any number of operators at non-specialized workstations.

CEIA inspection equipment communicates with the management system via an encrypted channel (AES-1) on a standard shareable Ethernet network connection. Any number and combination of CEIA inspection devices can be added to the system.

With the NetID system you can control the operating parameters of the devices, check their operational status remotely and receive

automatic warnings if malfunctions or anomalous situations occur.

All results from CEIA inspection equipment are transmitted and stored in a centralized database for further analysis, which can be carried out using NetID applications. Analysis results can be exported in standard formats.

In the event of gamma-ray source detection, the NetID system immediately sends a signal via the NetID Monitor display showing the signal record of the device involved and other information which will help to identify the subject that has triggered the alarm.

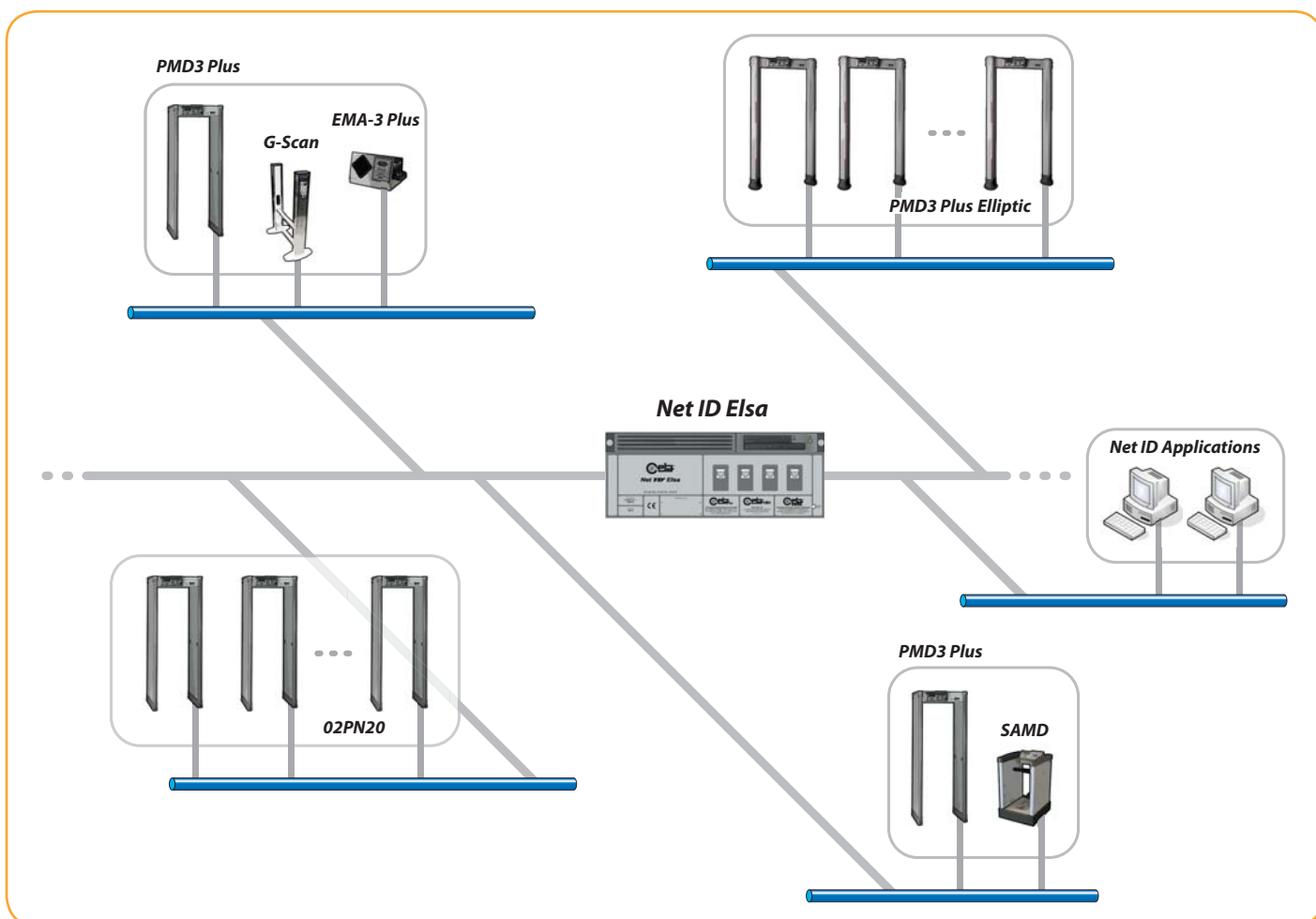

www.ceia.net

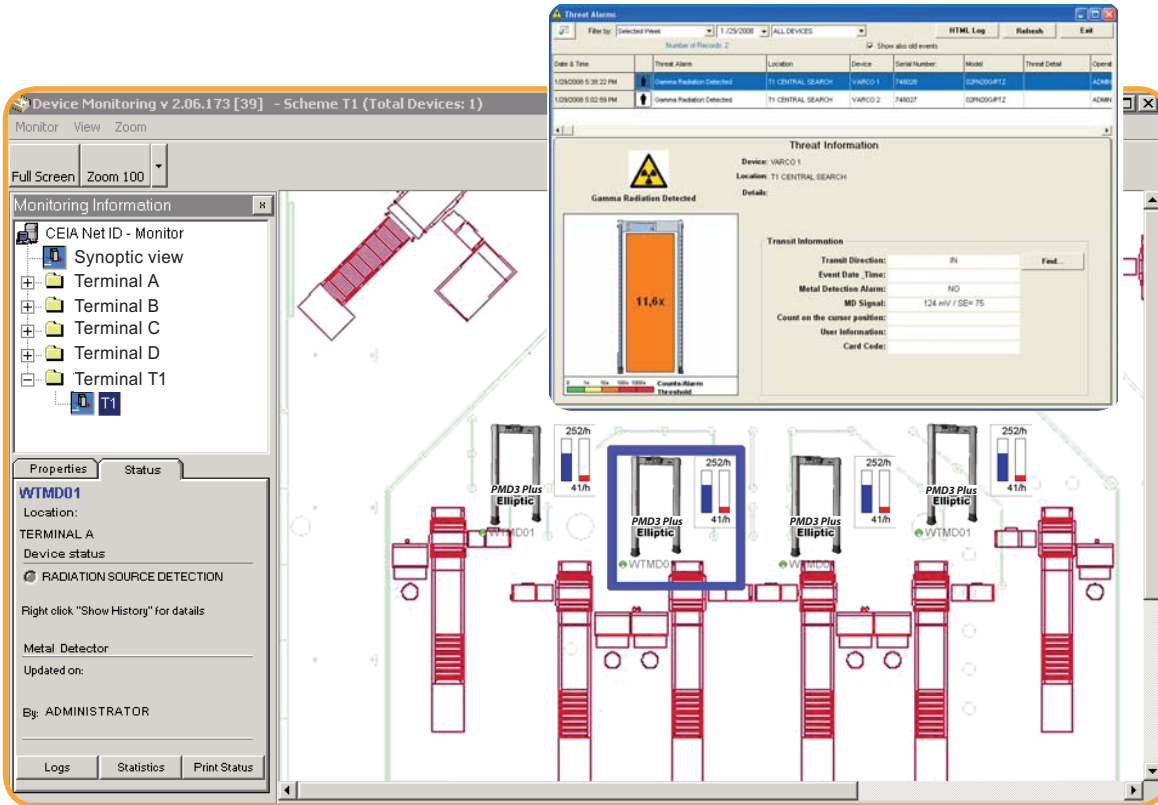

Device Monitoring v 2.06.173 [39] - Scheme T1 (Total Devices: 1)

Monitor View Zoom

Full Screen Zoom 100

Monitoring Information

- CEIA Net ID - Monitor
- Synoptic view
- Terminal A
- Terminal B
- Terminal C
- Terminal D
- Terminal T1

Properties Status

WTMD01

Location: TERMINAL A

Device status: **RADIATION SOURCE DETECTION**

Right click "Show History" for details

Metal Detector

Updated on:

By: ADMINISTRATOR

Logs Statistics Print Status

Threat Alarm

Filter by: Connected/Power 1/25/2008 ALL DEVICES HTML Log Refresh Exit

Date & Time	Threat Alarm	Location	Device	Center Number	Model	Threat Detail	Event
12/20/08 5:38:22 PM	Gamma Radiation Detected	T1 CENTRAL SEARCH	WTMD01	FAN02	ICPND05P1Z		ADMIN
12/20/08 5:32:59 PM	Gamma Radiation Detected	T1 CENTRAL SEARCH	VARCO2	FAN027	ICPND05P1Z		ADMIN

Threat Information

Device: VARCO1

Location: T1 CENTRAL SEARCH

Details:

Gamma Radiation Detected

Count: 11,6x

Transit Information

Transit Direction: IN Find...

Event Date / Time:

Metal Detection Alarm: NO

MS Signal: 124 mV / SE=75

Count on the cursor position:

User Information:

Card Code:

DETAILED ANALYSIS OF DETECTION OF A RADIOACTIVE SUBSTANCE



GATE 1

Count / Alarm Threshold

10000

1000

100

10

1

0

17.36.21 17.36.27 17.36.33 17.36.39 17.36.45 17.36.51 17.36.57 17.37.03 17.37.09 17.37.15 17.37.21 17.37.27 17.37.33 17.37.39 17.37.45 17.37.51 17.37.57 17.38.03 17.38.09 17.38.15 17.38.21 17.38.27 17.38.33 17.38.39 17.38.45 17.38.51 17.38.57 17.39.03 17.39.09 17.39.15 17.39.21 17.39.27 17.39.33 17.39.39 17.39.45 17.39.51 17.39.57 17.40.03 17.40.09 17.40.15 17.40.21

from 17.36.21 to 17.40.21 date: 12/18/2008

Count in cursor position: 11,6 x [Alarm Threshold] Maximum count: 11,6 x [Alarm Threshold]

Zone 1 4,8

Zone 2 11,6

Zone 3 10,6

Zone 4 10,9

Zone 5 4,0

Count per zone in the cursor position

0 1x 10x 100x 1000x

Alarm Threshold: IEC 62244

Speed

Rotate 0

12/18/2008 - 17.38.19

12/18/2008 - 17.38.20

12/18/2008 - 17.38.21

PMD3 Plus Elliptic®



TECHNICAL FEATURES

WALK-THROUGH GATE STRUCTURE

State-of-the-art, compact elliptical columns
Made entirely of advanced technical materials
Extremely robust, elegant and lightweight
Protected against aging, weather and wear-and-tear

TOTAL DIMENSIONS:
1065 x 360 x 2250 mm (WxDxH)

TRANSIT AREA: 720 x 2040 mm (WxH)

CENTRAL CONTROL UNIT

Ergonomic and robust design
High Visibility alphanumeric display and programming keyboard
Made of advanced plastics (IP20 protection degree) or stainless steel (AISI 316L - IP65 protection degree)

Access to the front panel protected by hardware key

TOTAL DIMENSIONS: 387 x 80 x 178 mm (WxDxH)

ALARM SIGNALLING

10 programmable acoustic tones. Intensity programmable to 10 levels, with max. pressure of 90 dB (A) at 1 m

Green and red optical bar-graph display, readable at 6 m. under 4000 lux of ambient light:

- Indication proportional to the transiting metal mass
- Indication proportional to the intensity of the transiting gamma source (only when local mode is selected)

Height-of-transit display bar equipped with 20 independent multicolor indicators for:

- "System Ready" signal (green lights)
- Position signalling of the detected metal mass (red light)
- Position signalling of the detected gamma emitting source (blue lights if local mode is enabled)

PROGRAMMING

LOCAL by Control Unit alphanumeric display and keyboard

REMOTE via RS-232 or Ethernet networking connection

SECURITY LEVEL selectable through:

- International Standard (IS) command
- Chip card

Programming and chip card access protected by (user and super-user) password

OPERATIONAL FEATURES

Very high discrimination and transit flow rate, five or more times compared with other metal detection systems

Quick reset time, programmable from 0.2 sec.

Very high detection speed (up to 15 m/sec.)

Build-in operational and technical functional verification

One-touch key reading of inbound, outbound and Security Level Data

No initial or periodical calibration requirement

INSTALLATION DATA

Automatic synchronisation between two or more metal detectors with a reciprocal distance of down to 5 cm without the use of external cables

Build-in floor sensitivity adjustment function

Build-in general noise (GN) and electromagnetic noise (EN) digital read-out

POWER SUPPLY: 95 ÷ 264 VAC, 50 ÷ 60 Hz, 40 VA

ENVIRONMENTAL DATA

PROTECTION DEGREE

- Indoor Model: IP20 - IEC529
- Outdoor Model: IP65 - IEC529

OPERATING TEMPERATURE from -20°C to +70°C

STORAGE TEMPERATURE from -35°C to +70°C

RELATIVE HUMIDITY:

from 0 to 95% (without condensation)

CERTIFICATION AND COMPLIANCE

Tested and Certified as compliant with the applicable electromagnetic Standards on Human Exposure and pacemaker safety

Tested to and compliant with the detection requirements for Gamma Portals

Compliant with all Airport Security Standards worldwide

Approved by Ministries and Competent Governmental Authorities

Tested to and compliant with the applicable CE Standards for electrical safety and EMC

Harmless to magnetic media (floppy disks, tapes, etc.)

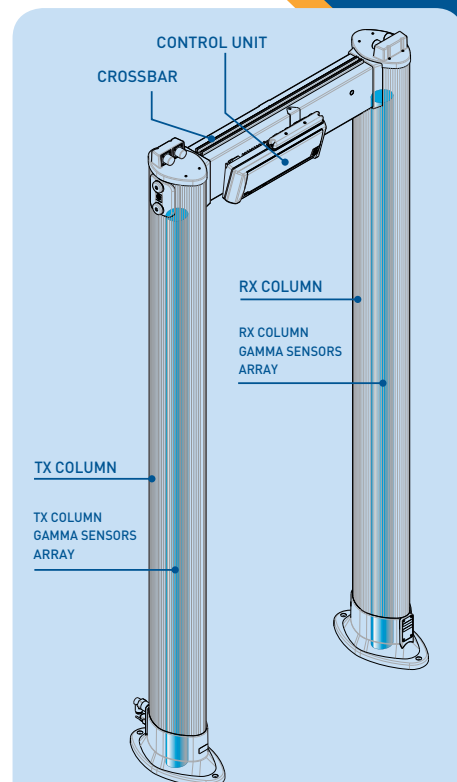

RELATED EQUIPMENT

G-SCAN: Hand-baggage inspection system for the detection of radioactive substances at the X-Ray scanner exit point. Available for various sizes of X-Ray tunnels.

METAL DETECTOR SPACER: Divider between Metal & Gamma Detectors and X-Ray scanners, specifically designed to optimize system compatibility (strongly recommended for X-Ray scanner applications). Dimensions: 35 x 65 x 129 cm (WxDxH)

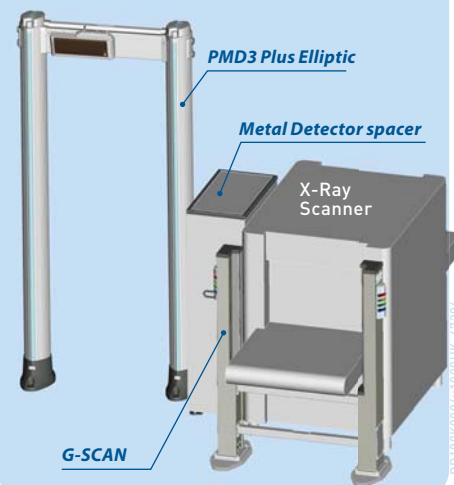

Zona Industriale 54/G, 52041 Vicinaggio - Arezzo (ITALY)
Tel.: +39 0575 4181 Fax: +39 0575 418298 E-mail: infosecurity@ceia-spa.com

www.ceia.net